

## **KritiScan™ 6550** - Multi-energy X-ray Baggage Scanner



**Color Image**



**Black & White**



### **About KritiScan™ 6550**

KritiScan 6550 is the Multi-energy X-ray baggage scanner designed and developed by Vehant Technologies with Tunnel size - 650 mm (W) X 500 mm (H). It is a compact X-ray baggage scanning system ideal for checkpoints and small baggage scanning at high security premises such as Airports, Government offices, Railways, MRTS and other baggage scanning applications. KritiScan offers numerous optional features such as Threat Image Projection (TIP), Network Supervisory Workstation (NSW) & Video management for effective operation.

#### **SALIENT FEATURES**

- Radiation safe as per AERB India
- High density alert feature
- Distortion correction through software
- Self-diagnosis feature
- Multi-energy high penetration
- Central supervisor console (Optional)
- Threat Image Projection (Optional)
- Energy Saving device (Optional)

# Technical Specifications

<b>Image Processing</b>	<ul style="list-style-type: none"> <li>• Color / Black &amp; White</li> <li>• Multi-energy</li> <li>• Organic/Inorganic Strip</li> <li>• Edge Enhancement</li> </ul>	<ul style="list-style-type: none"> <li>• Super Enhancement</li> <li>• Negative Image</li> <li>• H/L Penetration</li> <li>• Gray Level Scanning</li> </ul>	<ul style="list-style-type: none"> <li>• Pseudo Color</li> <li>• High Density Alert</li> </ul>
<b>Material Classification</b>	<ul style="list-style-type: none"> <li>• Organic: Orange</li> <li>• Metal: Blue</li> </ul>	<ul style="list-style-type: none"> <li>• Light Metal and Mixture: Green</li> <li>• High Density Material: Black</li> </ul>	
<b>Zoom</b>	<ul style="list-style-type: none"> <li>• 32x/64x</li> </ul>		
<b>Double - screen Display</b>	<ul style="list-style-type: none"> <li>• Double-screen Joint Display</li> </ul>	<ul style="list-style-type: none"> <li>• Color + Black &amp; White Display</li> </ul>	<ul style="list-style-type: none"> <li>• Double-screen Copy Display</li> </ul>
<b>Image Recall</b>	<ul style="list-style-type: none"> <li>• 20 Screens or better</li> </ul>		
<b>Image Storage</b>	<ul style="list-style-type: none"> <li>• 100000 images</li> <li>• Image Simulated Playback</li> </ul>	<ul style="list-style-type: none"> <li>• Image Search</li> <li>• Image Export</li> </ul>	
<b>Additional Features</b>	<ul style="list-style-type: none"> <li>• Baggage Counter</li> <li>• Multi-level user Management</li> <li>• System Work Time Counter</li> <li>• Self-diagnosis</li> </ul>	<ul style="list-style-type: none"> <li>• User Report Management</li> <li>• Maintenance Warning</li> <li>• X - Ray Work Time Counter</li> </ul>	
<b>Optional Features</b>	<ul style="list-style-type: none"> <li>• Threat Image Projection</li> </ul>	<ul style="list-style-type: none"> <li>• Central Supervisor Console</li> </ul>	
<b>Display</b>	<ul style="list-style-type: none"> <li>• High Resolution 17" TFT/customizable as required</li> </ul>		

## Equipment Specifications

Tunnel Size	- 650mm (W) * 500mm (H)
Conveyor Speed	- 0.2/0.3 m/s
Max. Conveyor Load	- 160kg (evenly distributed)
Storage Temperature/Humidity	- -20° ~ +60°C / 10% ~ 95% (Non-condensing)
Working Temperature/Humidity	- -5°C ~ +50°C / 10% ~ 95% (Non-condensing)
Working Voltage	- AC 220V, 50Hz
Power	- 2.2kVA

## Performance Index

Line Resolution	- 42 SWG/38 AWG
Steel Penetration	- 35 mm
Image Resolution	- 1280x1024 pixels

## X - Ray Generator

X - Ray Direction	- Upward
Tube Voltage	- 100 - 160kV (Adjustable)
Tube Current	- 0.3 ~ 1.2 mA (Adjustable)
Cooling / Duty Cycle	- Sealed Oil Cooling/100%

\*specifications are subject to change without prior notice  
# All dimensions are in millimeter unit

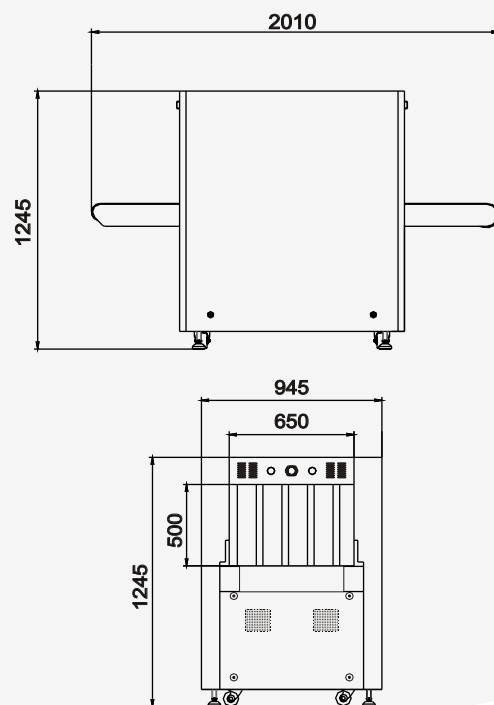

## CONTACT US

**Vehant Technologies Pvt. Ltd.**

B-73, Sector-57, Noida,  
Uttar Pradesh, India

+91-120-4610200

+91-120-4610299

contact@vehant.com

[www.vehant.com](http://www.vehant.com)